

# INTRODUCTION MANUAL

## All-in-one Solar street light

### 1. Product introduction

The integrated LED solar street lamp uses solar energy as electricity supply to provide lighting at night. All-in-one design, integration light source, high capacity lithium battery and automatic controller integration, which has advantages in high brightness, environmental protection, easy installation, long life span, etc. This product uses solar energy to convert into electrical energy to charge the battery during the day, and discharges at night to make it work. Widely used in urban roads, industrial parks, scenic spots, parks, squares, other places.

### 2. Features

All-in-one solar street light adopts solar power supply in order to save electric energy and protect the earth's resources.

### 3. Working mode

Light control mode: the street light doesn't work during the day, when the solar panel charges the battery. Light at night in 100% brightness.

### 4. Product Features

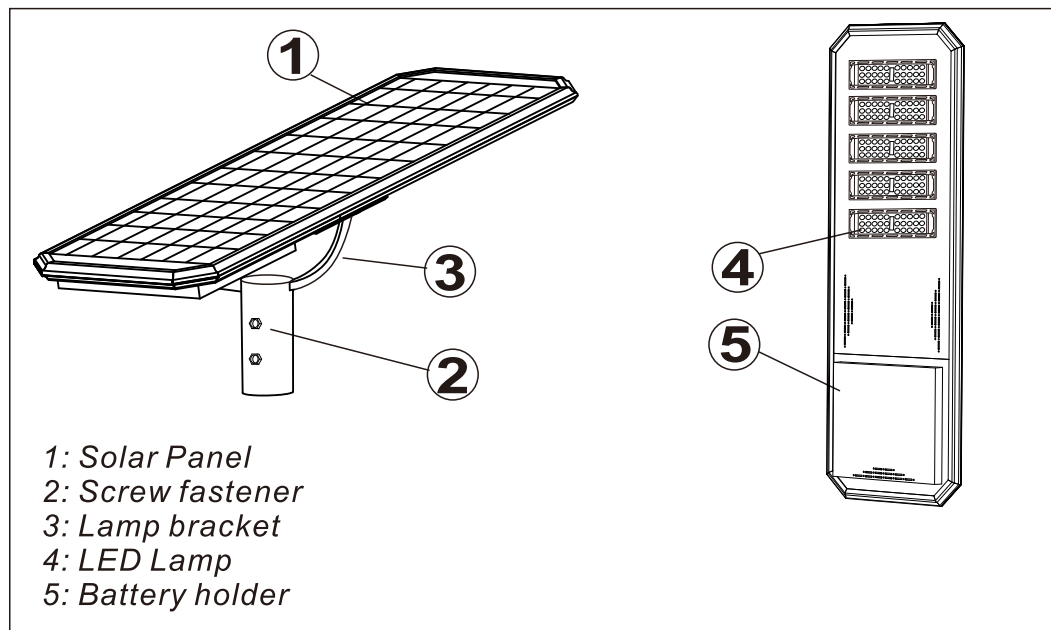

### 5. Installation process

- 1 Choose the best place for lighting. Light poles should use iron or steel poles with the height in 4-12m, diameter in 50-80mm, and a wall thickness greater than 2.0mm.
- 2 Please check if the parts are complete.
- 3 Put the lamp into the pole, and fasten the anti-theft screw with tools, and make sure the lamp is stable.

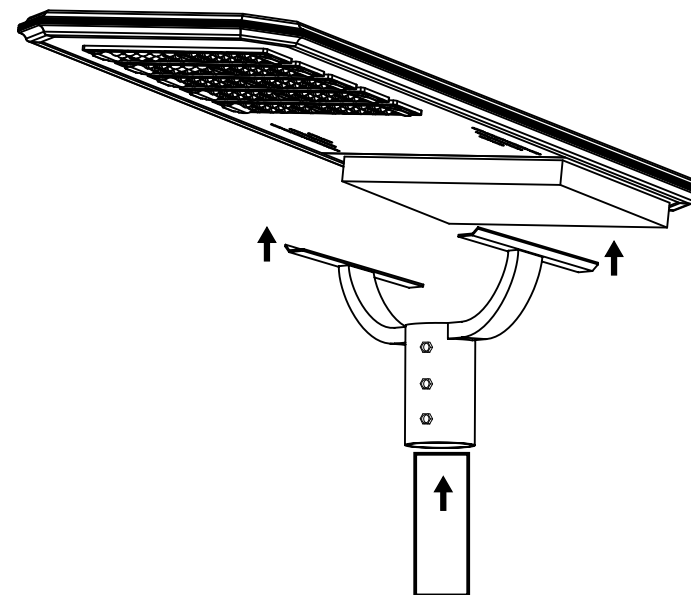

### 6. Specification

Model	LA1	LA2	LA3
Luminous Flux	1800LM	2400LM	3000LM
Mono Solar panel	50W	65W	80W
Battery	3.2V60AH	3.2V80AH	3.2V90AH
Lamp Size	1005*385*65MM	1175*385*65MM	1427*385*65MM
LED Quantity	200PCS	250PCS	300 PCS
Solar Panel Size	953*335MM	1125*335MM	1377*335MM
Height of installation	4-5M	6-8M	8-10M
Waterproof Level	IP66		
Charging time	4-5H		
Working time	>20H		
Emitting angle	75°*155°		
Lighting mode	Lighting control+Sensor		
RA	≥80		
Color temperature	6500K		